

User manual
CRM 3000

ti DualInventive
Ubiquitous Rail

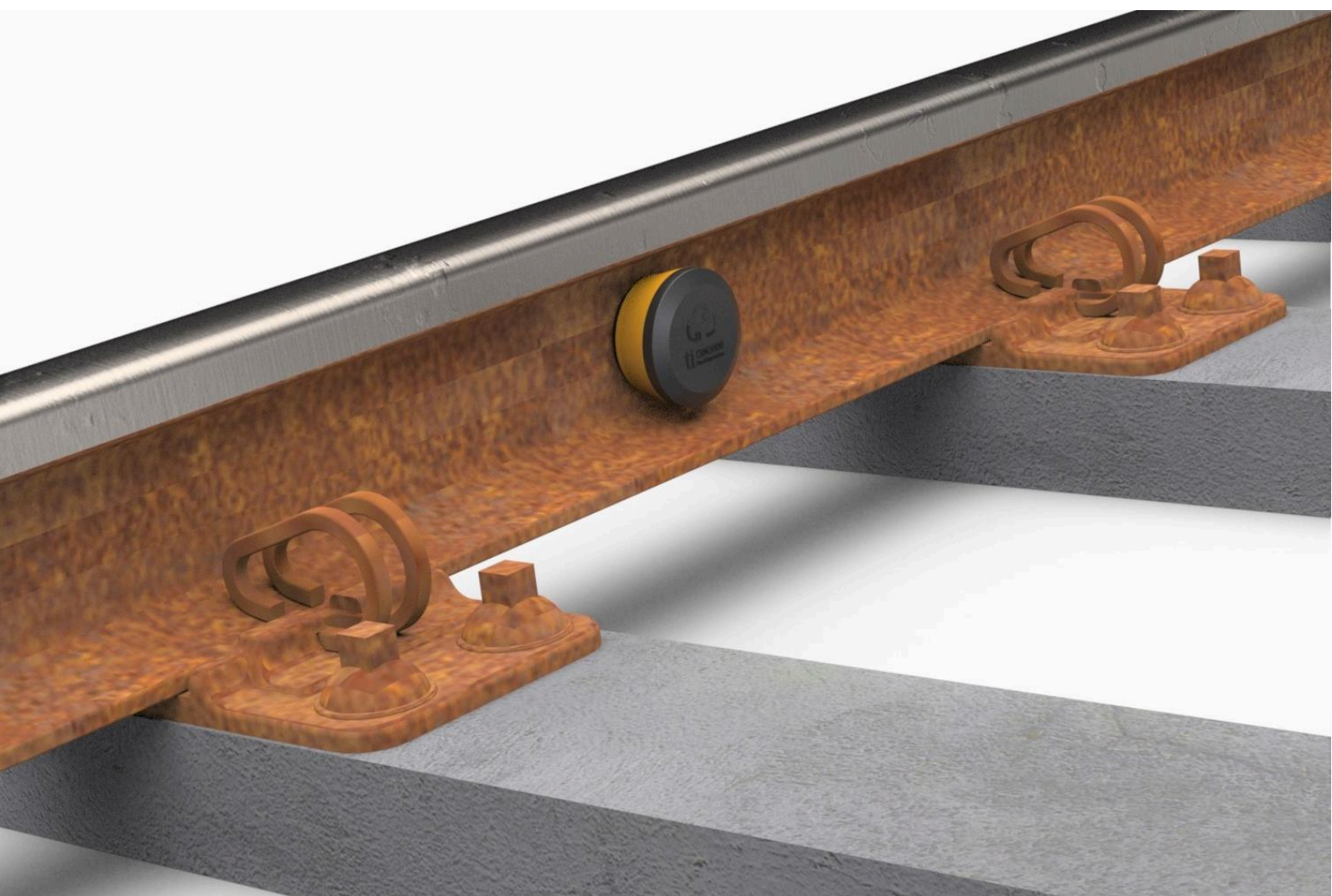

DUAL INVENTIVE | BELGIËSTRAAT 5 | 5061 KG OISTERWIJK

Telephone: +31 (0)13 5339969

Email: info@dualinventive.com

Website: dualinventive.com

Date: November 2022

Version: 1.0

User manual: original

TABLE OF CONTENTS

1	Preface	4
1.1	Purpose user manual.....	4
1.2	User.....	4
1.3	Vulnerable persons.....	4
1.4	Reading guide.....	5
1.5	Abbreviations.....	5
2	Introduction.....	6
2.1	Intended use.....	6
2.2	Non-intended use.....	6
2.3	Lifespan.....	6
2.4	Warranty and delivery conditions.....	6
2.5	Specifications.....	7
2.5.1	CRM 3000.....	7
2.5.2	Insight.....	7
2.6	Worksite.....	7
3	Product description.....	8
3.1	CRM 3000.....	8
3.2	Identification.....	9
3.3	Insight web and the app 'The RailCloud - Work Management'.....	9
3.4	Terms of use.....	9
3.4.1	CRM 3000.....	9
3.4.2	Insight web and the app.....	9
4	Safety.....	10
4.1	General.....	10
4.1.1	Intended use.....	10
4.1.2	Non-intended use.....	10
4.2	General safety instructions.....	10
4.3	Residual risks.....	10
4.4	Personal Protective Equipment.....	10
4.5	Safety symbols.....	11
5	Installation.....	12
6	Insight web.....	13
6.1	Icons and actions.....	13
6.2	Getting started.....	14
6.3	Overview Insight.....	16
6.4	Asset map and asset details.....	17
6.4.1	Asset info.....	20
6.4.2	Attributes.....	20
6.4.3	Sensors.....	21
6.4.4	Alarm.....	21
6.4.5	Alarm details.....	21
6.4.6	Thresholds.....	22
6.4.7	History.....	22
6.5	Asset overview.....	23

6.6	Asset list.....	25
6.7	Dashboards.....	26
6.7.1	Creating dashboards.....	26
6.7.2	Creating widgets.....	27
6.7.3	Editing dashboards.....	28
6.8	Virtual objects.....	29
6.8.1	Creating virtual objects.....	29
6.8.2	Adding virtual objects.....	31
6.8.3	Removing virtual objects.....	31
6.9	Thresholds.....	32
6.9.1	Temperature.....	33
6.9.2	Orientation detection.....	34
6.9.3	Setting a threshold on multiple CRM 3000s at once (maximum of 10).....	35
6.9.4	Setting a threshold on all CRM 3000s at once (more than 10).....	36
6.10	Setting up notification channels.....	37
6.10.1	Creating notification channels.....	37
6.10.2	Editing notification channels.....	38
7	App 'The RailCloud - Work Management'	39
7.1	Installing.....	39
7.2	Logging in.....	39
7.3	Enabling / disabling personal notifications.....	39
7.4	Map features.....	40
8	Changing locations.....	41
8.1	Changing manually locations.....	41
8.2	Synchronizing with a smart device's location.....	41
9	Troubleshooting	42
10	Service	43
11	Contact details	44

1 PREFACE

Please read this manual carefully. The correct understanding and execution of the instructions is obligatory for using the CRM 3000 safely and correctly. Always keep this manual near the CRM 3000, so you can use it at any moment.

This manual is also available on <https://www.dualinventive.com/en/downloads>.

If you encounter any ambiguities while using the CRM 3000, we invite you to report them via info@dualinventive.com or by telephone. Ultimately, the product should make you happy and we like to work hard for that. Your response will contribute to a better safety and distribution of rail capacity. On behalf of the Dual Inventive team, we wish you a lot of track monitoring with the CRM 3000.

To support the use of the CRM 3000, resources have been made available by Dual Inventive. Please consult <https://www.dualinventive.com>.

No rights can be derived from the information in this user manual. The reproduction or distribution in printed, written and/or audio-visual form is prohibited, unless Dual Inventive has permitted this beforehand.

Dual Inventive has originally written this manual in English. If anything is unclear or deviates from the original in a translated version, the original English document is leading.

1.1 Purpose user manual

The purpose of this user manual is to instruct the user on the correct and safe use of the CRM 3000. The CRM 3000 is a sensor for the remote monitoring of railway systems, used in combination with the web and app application versions of Insight.

This user manual contains instructions regarding the:

- personal safety and product safety that must be observed to avoid risks that could lead to physical and/or property damage;
- use of the CRM 3000.

1.2 User

Typical users of the CRM 3000 are:

- the work planner who prepares and manages the web interface Insight and assigns the location for installing the CRM 3000s on the railway track;
- the installer, the track worker who installs the CRM 3000 on the railway track.

Every user of the CRM 3000 must be authorized by the administrator of the user's company for the right access and user rights for Insight.





1.3 Vulnerable persons

The CRM 3000 may not be used by persons:

- younger than 18 years;
- with reduced physical, sensory or mental capabilities;
- with a pacemaker, because the CRM 3000 has a strong magnet.

1.4 Reading guide

To alert the reader to safety issues and important information, the following symbols and terms are used in this manual:

SYMBOL	MEANING
	DANGER Indicates a hazardous situation which could result in death or serious injury if the safety instructions are not followed.
	WARNING Indicates a hazardous situation which could result in death or serious injury and/or damage to the product or the surrounding area if the safety instructions are not followed.
	CAUTION Indicates a hazardous situation which could result in minor and/or moderate damage to the product or the surrounding area if the safety instructions are not followed.
	NOTE Provides important information.
	NOTE Refers to a document.

1.5 Abbreviations

ABBREVIATION	MEANING
CRM 3000	Critical Rail Monitor 3000
NBIoT	Narrow Band Internet of Things
PPE	Personal Protective Equipment

Table 1-1: Abbreviations

2 INTRODUCTION

2.1 Intended use

The CRM 3000 is intended to remotely monitor railway systems. The CRM 3000 measures the rail temperature and its orientation on the track. The CRM 3000 is used in combination with the Insight web interface (Insight web) and the Insight app 'The RailCloud - Work Management'. Both applications are used for monitoring and management of one or more CRM 3000s.

2.2 Non-intended use

Any other use than the intended use is prohibited.



WARNING

Non-intended use could have consequences for the personal safety and can cause material damage to the CRM 3000 and its surroundings.



NOTE

In case of non-intended use, the warranty of the CRM 3000 is voided.

2.3 Lifespan

Generally, the CRM 3000 is designed to be maintenance free for 5 years. This may vary depending on the area that the device is used in.

2.4 Warranty and delivery conditions

Dual Inventive's products are carefully manufactured from high-quality materials. The CRM 3000 is supported by a lease contract that contains Dual Inventive's general and lease conditions.

2.5 Specifications

2.5.1 CRM 3000

SPECIFICATION	VALUE
Compatible rail profiles	<ul style="list-style-type: none"> All rail profiles
Weather conditions	<ul style="list-style-type: none"> All weather conditions
Telecommunication	<ul style="list-style-type: none"> NB IoT
Temperature measurements	<ul style="list-style-type: none"> Between -25 °C and +70 °C Accuracy of 0.5 °C.
Positioning measurements	<ul style="list-style-type: none"> Through X, Y and Z coordinates
Frequency of measurements	<ul style="list-style-type: none"> Every 5 minutes Update sent to Insight every hour
IP protection level	<ul style="list-style-type: none"> IP 65
Weight	<ul style="list-style-type: none"> 310 g
Dimensions	<ul style="list-style-type: none"> Height: 45 mm Diameter: 80 mm
Battery life	<ul style="list-style-type: none"> > 5 years

Table 2-1: Specifications CRM 3000

2.5.2 Insight

SPECIFICATION	VALUE
Internet	<ul style="list-style-type: none"> Broadband
Computer	<ul style="list-style-type: none"> Processor at least 1.5 GHz Internal memory at least 2,048 MB Video card at least 512 MB Screen resolution of at least 1,366p by 768p
Web browser	<ul style="list-style-type: none"> Google Chrome latest version (recommended) Microsoft Edge latest version
Recommended software	<ul style="list-style-type: none"> Adobe Acrobat as PDF reader to view reports

Table 2-2: Specifications Insight



NOTE

If the requirements for the needed software and hardware are incorrect or absent, Dual Inventive is not responsible for the consequences.

2.6 Worksite

Always ensure your own safety when entering the railway environment. Follow the applicable local regulations and organizational procedures. Please feel free to define your own labour rules in addition to these regulations and procedures.

3 PRODUCT DESCRIPTION

3.1 CRM 3000

The CRM 3000 is a sensor for remote monitoring of railways. The device has an internal battery with an expected lifetime of 5 years. For the user, the CRM 3000 is a 'black box'. It cannot be opened and the device does not have control buttons. The compact CRM 3000 is magnetically attached to the object to be monitored, so installation is simple and fast.



POS.	LEGEND	POS.	LEGEND
1.	Top view	3.	Front view with identification
2.	Bottom view		

Figure 3-1: CRM 3000

The CRM 3000 measures the temperature of the object and its own orientation through X, Y and Z coordinates. The temperature measurement is intended for reliable monitoring of changes in rail and object temperatures. The orientation measurement is intended to monitor the alignment of objects, such as signs, relay cabinets or signals. The orientation measurements can also be used to indicate whether the CRM 3000 has fallen off or has been removed from the object.

The CRM 3000 communicates with Insight using NBloT technology. The measured values are reported back to the user via Insight. In this way, users can both monitor and manage all CRM 3000 devices easily using the Insight applications.

3.2 Identification

The CRM 3000 has an ID sticker with a serial number and a QR-code (see Figure 3-1).

3.3 Insight web and the app ‘The RailCloud – Work Management’

The CRM 3000 is used in combination with Insight web and the app. See section 6 for the product description of Insight web and section 7 for the app.

3.4 Terms of use

3.4.1 CRM 3000

1. Do not use the CRM 3000 if it has been damaged or shows defects. The CRM 3000 should not have major damage; a slight scratch is acceptable. Quarantine the CRM 3000. Please contact Dual Inventive.
2. Never perform repairs to the CRM 3000 yourself. Please contact Dual Inventive’s service department for repairs.
3. Make sure that when installing the CRM 3000, the device does not get damaged by on track equipment or other tools in line with local regulations.
4. Avoid dropping the CRM 3000. The device contains components that can withstand shocks and vibrations, but the device can break down.

3.4.2 Insight web and the app



WARNING

Always respond to service alerts from devices when something is not working correctly.

1. You may only use Insight when you are authorised by the user company for the right access and user rights. Dual Inventive creates a user account for the company. This user account is the company’s administrator and is the nominated contact person for your company. The administrator is responsible for creating and managing users and their respective rights for using Dual Inventive product(s), in such a manner that misuse is avoided. You are responsible for keeping your password secret and working safely with Dual Inventive products.
2. If you have lost login details, immediately contact the company administrator within your organization to block the account to avoid misuse. If internet is available, please go to Insight and change the password to avoid misuse.
3. Incompatible hardware, software settings, firewalls etc. could limit the connection to Insight. When you encounter any issues, please discuss it with your IT staff.
4. See Table 2-2 and visit <https://www.dualinventive.com> to find out which browsers and devices are supported by Insight and the app. If needed, request support from Dual Inventive.
5. To use the functionality of the CRM 3000, a stable NBloT connection is needed. In areas with a poor NBloT connection, the CRM 3000 may lose its connection to Insight. This means that no data is transmitted to Insight.
6. To use the functionality of the app, use a compatible mobile phone (see section 7.1).
7. While creating dashboards, make sure an internet connection is present.

4 SAFETY

4.1 General

4.1.1 Intended use

For safe use, only use the CRM 3000 for its intended use.

4.1.2 Non-intended use

Non-intended use of the CRM 3000 can cause malfunctioning and unsafe situations like electrocution, fire or other dangerous situations.

4.2 General safety instructions

Specific safety instructions are part of the installation, preparation and configuration of the CRM 3000, which are described in these sections. In addition, follow these general safety instructions:

1. Installation of the CRM 3000 must be performed only when a worksite is protected from trains, in accordance with the relevant rail infrastructure controller's safe track access instructions.
2. Guarantee safety while installing the CRM 3000. The user is responsible for a safe installation. Follow the local, national and organizational regulations and procedures.



WARNING

The user is responsible for a safe installation of the CRM 3000.

4.3 Residual risks

Dual Inventive has performed a risk assessment of the CRM 3000 for the intended use and normal operating conditions. The following acceptable, residual risks are present with the intended use and the normal operating conditions:

HAZARD	RESIDUAL RISK
Magnetic field.	The CRM 3000 has a strong magnet to ensure a firm attachment to the rail or object. The magnetic field can damage electrical equipment. The magnetic field can disturb a pacemaker.

Table 4-1: Residual risks

4.4 Personal Protective Equipment

Due to the standard safety measures and PPE for track workers, there is no need for extra PPE while using the CRM 3000.

4.5 Safety symbols

In accordance with the residual risks, the CRM 3000 has the following safety symbols to warn the user:

SYMBOL	DESCRIPTION	WARNING
	<p>Dangerous for people with active implanted cardiac devices.</p>	<p>Users with a pacemaker are not allowed to use the CRM 3000.</p>

Table 4-2: Safety symbols

5 INSTALLATION

This section describes how to install the CRM 3000 in the track and to remove it from the track.



WARNING

Before installing, check the worksite and make sure that everything is safe. During installation, be aware of not trapping your fingers. Keep your fingers away between the device and the track and never put your fingers on the magnetic side.

Before installing the CRM 3000, ensure that the CRM 3000 is functioning properly by checking the temperature in Insight web (see section 6.4.3) or the app (see section 7.4). The last time the temperature has been updated, must be less than 2 hours ago and the measured temperature must be within the expected temperature range of its environment.

If the CRM 3000 is not working properly, wait one more hour because the data might be slightly delayed. If this does not help, contact Dual Inventive.

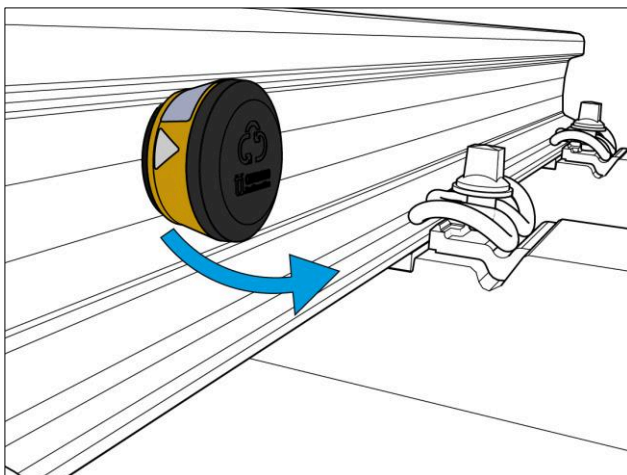
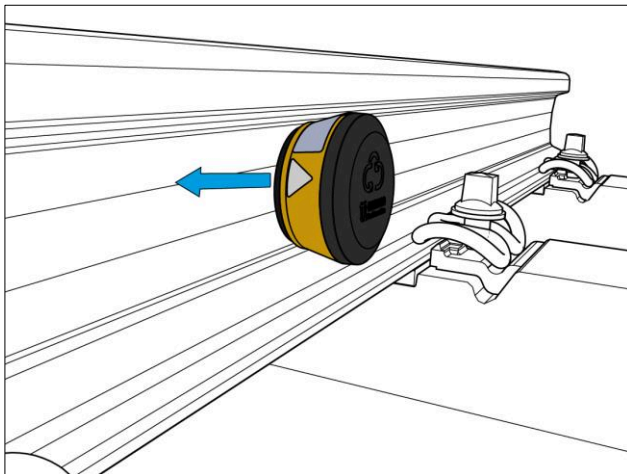

Figure 5-1: Installing and removing the CRM 3000

Installation:

1. Place the CRM 3000 on the shaded side of the rail to ensure that the rail temperature is measured correctly.
2. Place the CRM 3000 vertically so that the ID sticker can be read after placing.

Removal:

1. Place the thumb on the top of the device and grasp the bottom firmly with your fingers.
2. Pull up the device. If needed, use the foot of the rail as grip point for your fingers.



WARNING

Do not twist and turn the CRM 3000 while it is installed on the track or attached to another metal surface. This can permanently damage the device.

6 INSIGHT WEB

This section describes how to use Insight web for the CRM 3000.

6.1 Icons and actions

Insight uses a set of recurring icons for actions. Table 6-1 shows an overview and explanation of icons:









EXPLANATION	
	Create a new item such as a dashboard or widget.
	Edit an asset or asset details. The number on the bottom right shows how many assets have been selected.
	Select which data fields to see for the assets in the asset list.
	Draw an area on the asset map.
	Open the filter menu.
	Change the timeframe of a dashboard. The number on the bottom right shows the selected timeframe.
	Change to a windowed screen.
	Change to a full screen.
	Download data in csv format.

Table 6-1: Explanation of icons

6.2 Getting started

To use Insight, go to the MTInfo 3000 landing page (<https://www.mtinfo3000.com>):

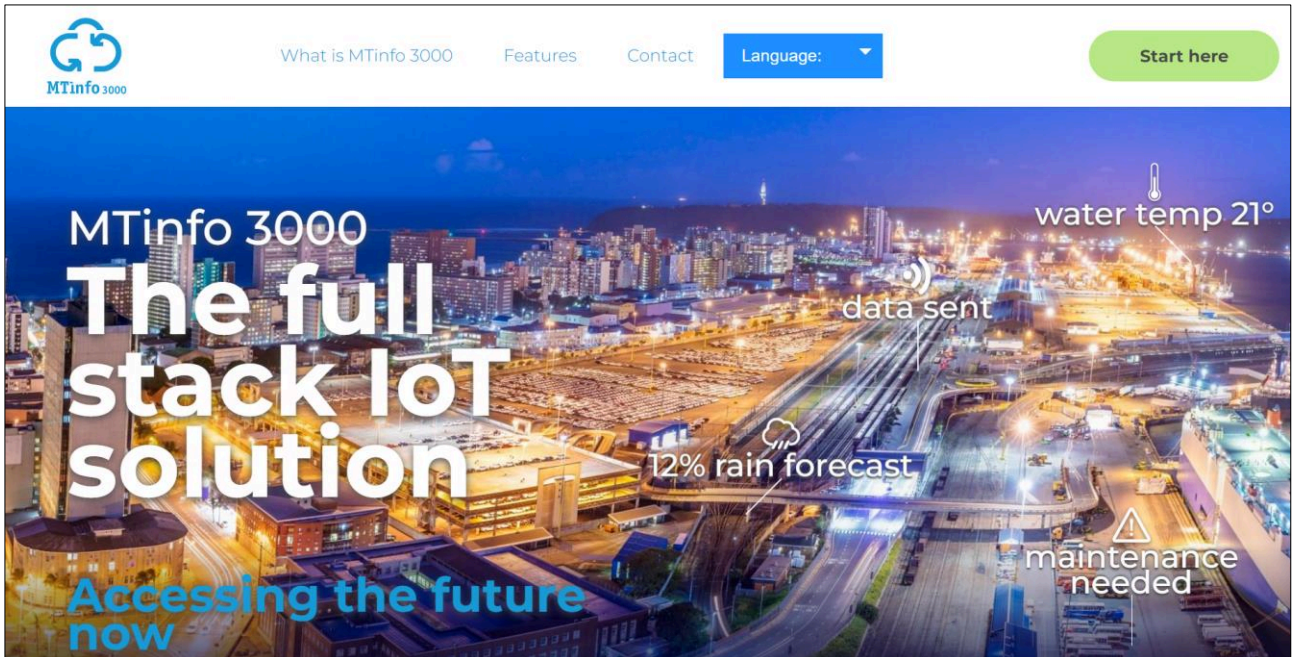

Figure 6-1: Landing page MTInfo 3000

1. Click 'Start here' in the upper right corner.

The window for signing in appears:



Figure 6-2: Signing in

2. Enter your Username, Company code and Password.
3. Click 'Accept agreement', read the 'IoTaaS Terms of Use MTInfo 3000' and accept them.
4. Sign in.

After signing in, the dashboard appears:

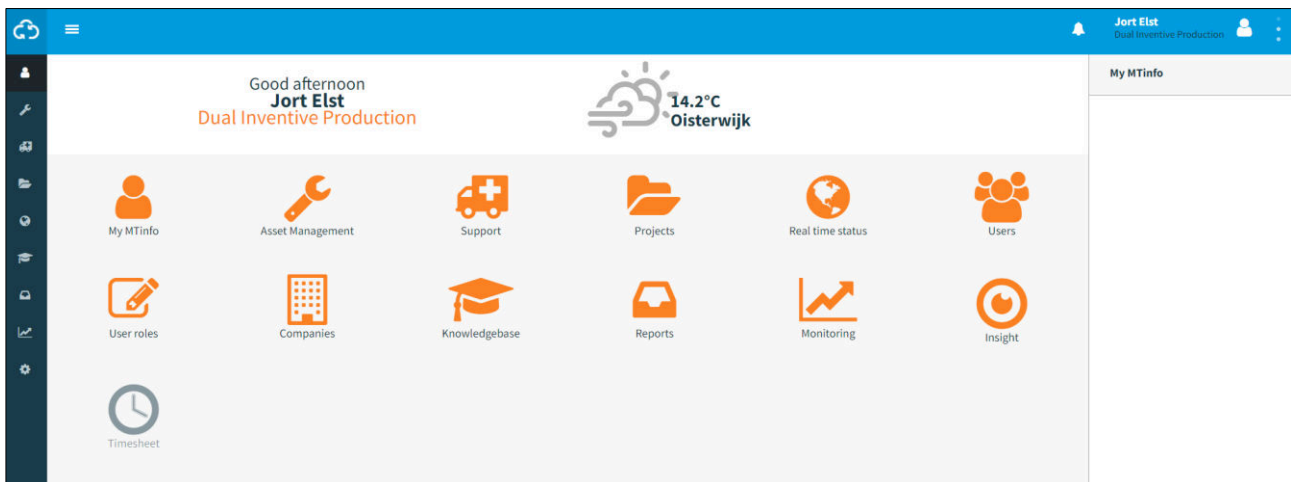

Figure 6-3: Dashboard



5. Click this button to access Insight. Alternatively, you can immediately log in via <https://mass.mtinfo3000.cloud/ri/>

6.3 Overview Insight

When opening Insight, the Asset Map (see section 6.4) is the default view:

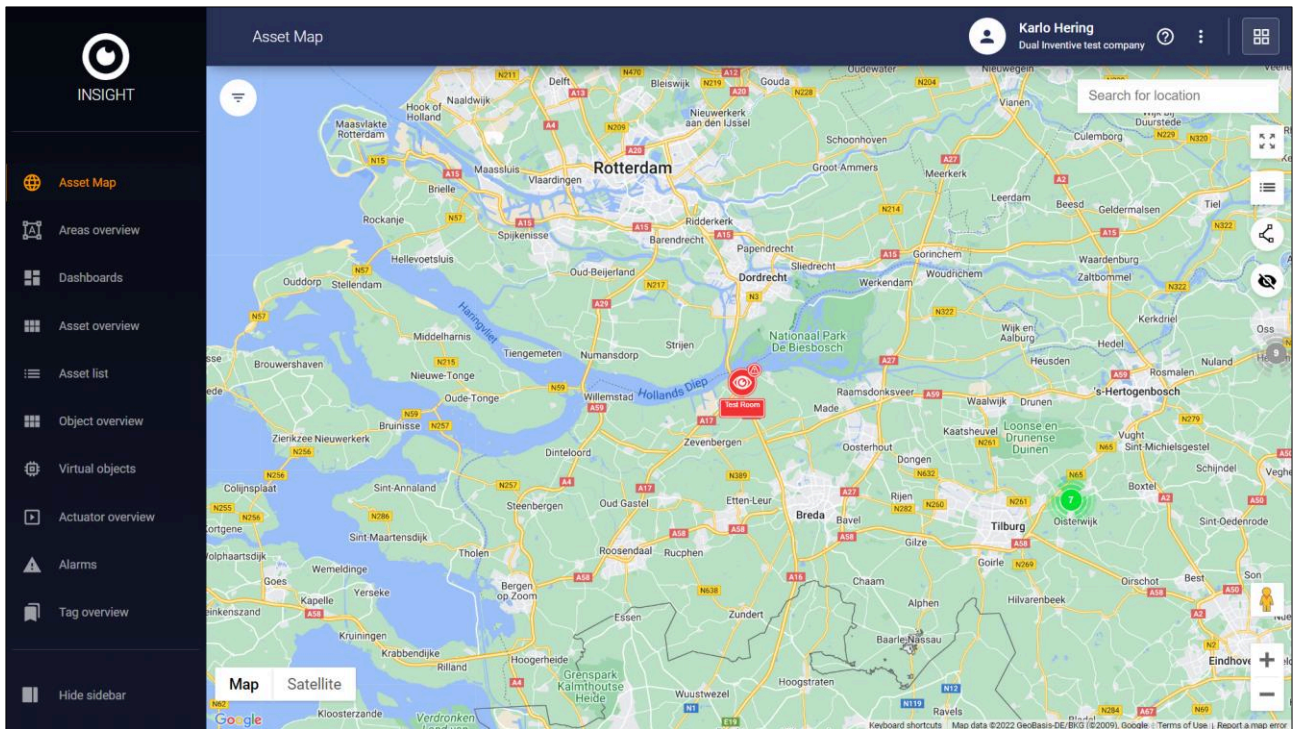





Figure 6-4: Overview insight

The Insight functions, on the menu on the left side, which are relevant to the CRM 3000, are explained in this manual. Some functions that are not applicable to the CRM 3000 are not covered.

Click on 'Hide sidebar' to hide the menu's text descriptions.

The top-right corner gives access to:

-  The Insight manual.
-  User settings and logout.
-  Provisioning, which is used to set up and administer assets, users, companies and notification channels (see section 6.10) in Insight.

6.4 Asset map and asset details

The Asset map shows the locations of CRM 3000 assets which have been set by the administrator or user:

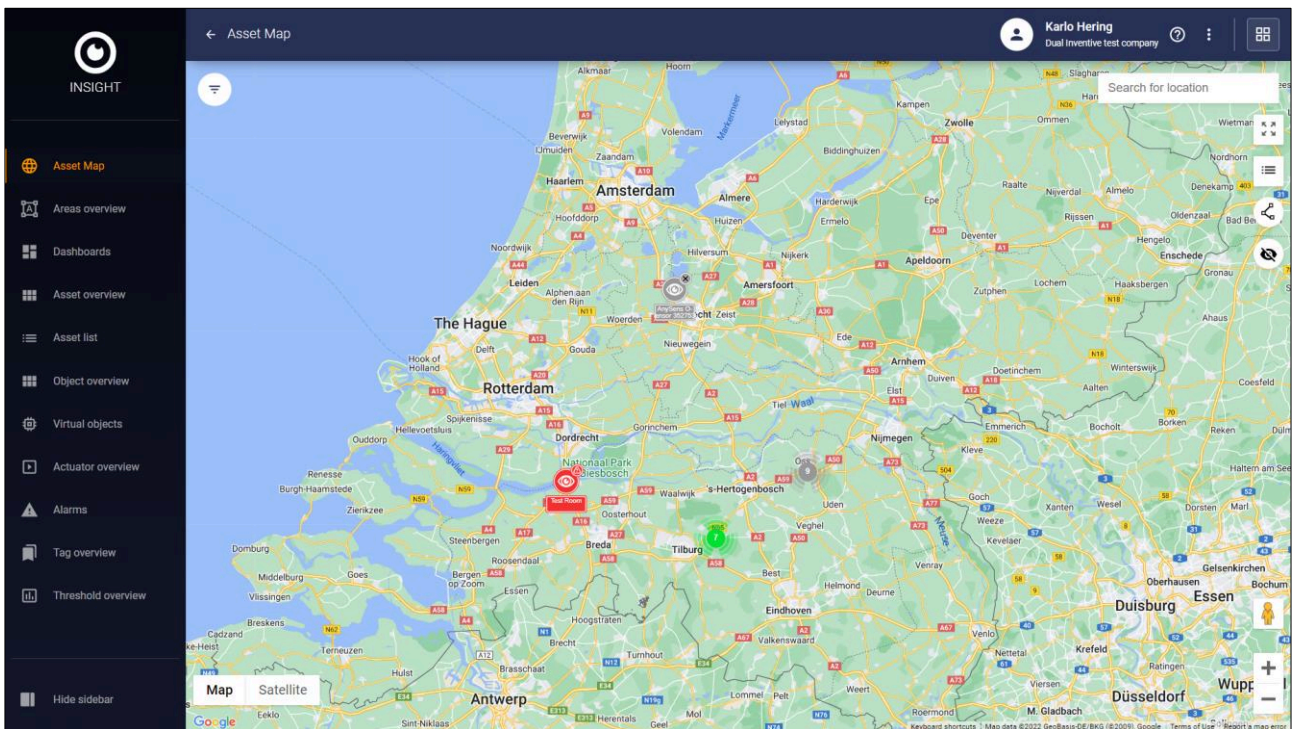

Figure 6-5: Asset map (filter is not used)

1. Use the filter to view more or less assets.
2. Click an asset to show its basic information.

The following screen appears:

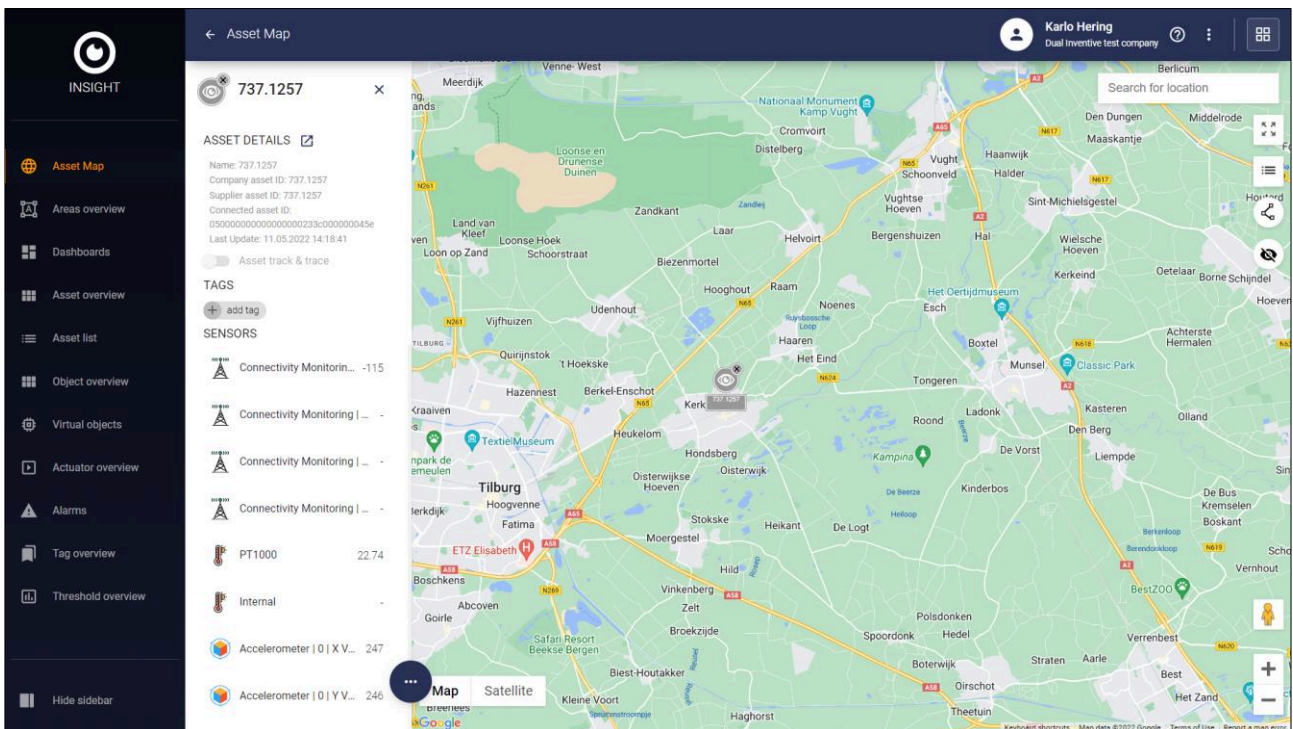



Figure 6-6: Asset map (filter is used)

 3. Click this icon to show the asset details.

The following screen appears:

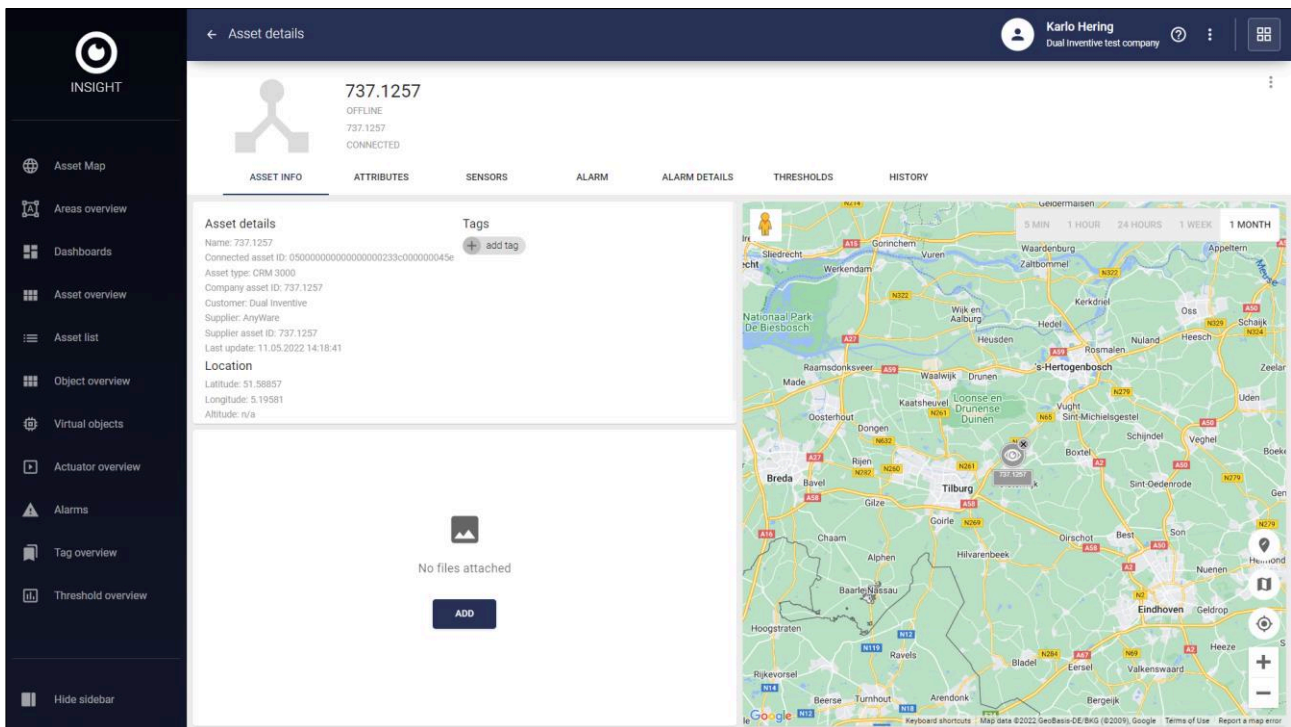



Figure 6-7: Asset details

Table 6-2 shows an overview of the menu items of Figure 6-7:

MENU ITEM	EXPLANATION
Asset info	Detailed information of the asset and its location.
Attributes	A list of all attributes of the asset.
Sensors	Historical sensor data can be visualised via line or bar charts with different aggregation types.
Alarm	History of alarms that were triggered by the asset.
Alarm details	Details of the triggered alarms per sensor value.
Thresholds	Threshold conditions can be set for each CRM 3000 to control when an alarm or notification is triggered.
History	History of the asset's events.

Table 6-2: Explanation of menu items



NOTE

The number of devices shown and their names may differ for your Insight environment.

6.4.1 Asset info

This screen shows the default information of a CRM 3000 such as its name, the customer, the supplier and the last update.

It is possible to add a tag or multiple tags to the device for easy filtering or identification of the device. Multiple CRM 3000s can be given the same tag which makes it easy to filter per group.

The map on the right side of the screen shows the set location of the device. With the period buttons (5 minutes to 1 month) you can view the device's location history, if applicable. The map is also used to change the location of a CRM 3000 (see section 8).

6.4.2 Attributes

Attributes are fields that can be used to add additional data to an asset, such as its production date and details about its location. These attributes are set up in Provisioning, which does not belong to the scope of this manual. Attributes are assigned to an asset type and can then be filled in per asset. You can view these attributes in Insight via this page.

6.4.3 Sensors

This screen shows the historical sensor data of an asset, such as the temperature:

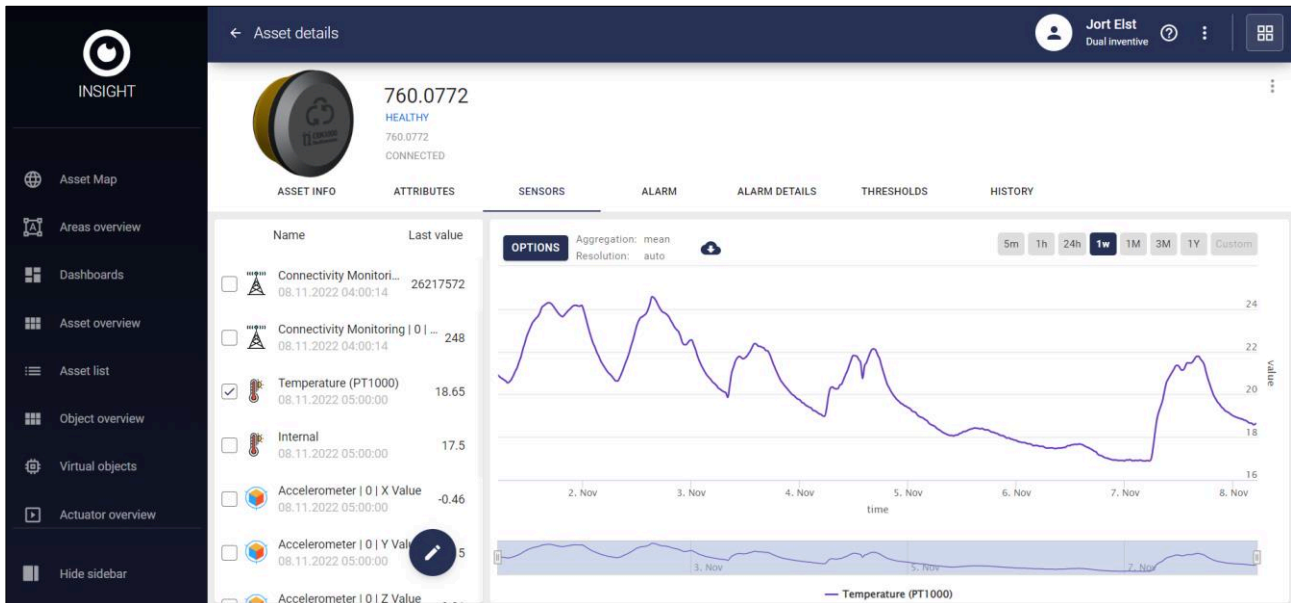



Figure 6-8: Sensors

This screen has the following possibilities to customise and retrieve data:

-  Download data in csv format.
-  Click this button to add or remove virtual objects (see section 6.8).

Adjust the period (5 minutes to 1 year) of the graph.

Select a period to zoom in. Click and hold the start time. Drag the cursor left or right to the end time and release the mouse button.

Select multiple sensor values at once to show them in one graph.

Select different types of data display options with the button [OPTIONS] and change the graph from line to bar.



NOTE

Dual Inventive recommends using the default display options for the CRM 3000 as much as possible.

6.4.4 Alarm

This screen shows the history of (in)active alarms that were triggered on the CRM 3000, paired with the timestamp and sensor value that have exceeded the threshold.

6.4.5 Alarm details

This screen shows for each sensor value how often the device has triggered an alarm. Like the sensors screen, select a period and zoom in.

6.4.6 Thresholds

Thresholds are intended to set one or more thresholds (see section 6.9) for the CRM 3000. A threshold generates a warning when a value measured by the CRM 3000 meets a set of criteria. When a threshold is exceeded, it is possible to receive an email or push notification via the app.

6.4.7 History

History shows a log of every action that was recorded by the CRM 3000, such as when it went in or out the alarm state. Filter by date and time to look for specific logs in the asset's history.

6.5 Asset overview

The Asset overview shows an overview with tiles of all available asset types:

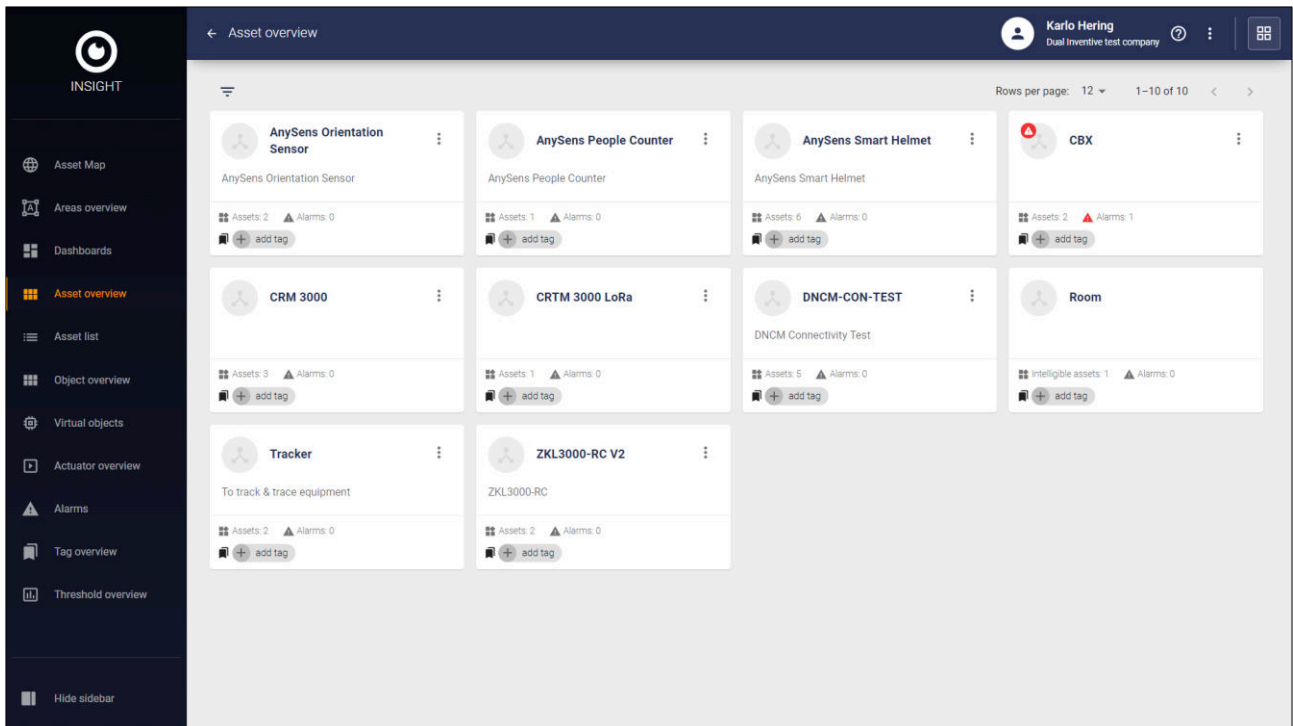





Figure 6-9: Asset overview

The Asset overview has the following possibilities:

-  Click this button to show the asset list (see section 6.6).
-  Click this button to add or remove virtual objects (see section 6.8).
-  Click this button to view all triggered alarms for that asset type.

Click 'CRM 3000' to show the details for all CRM3000s (see Figure 6-10).

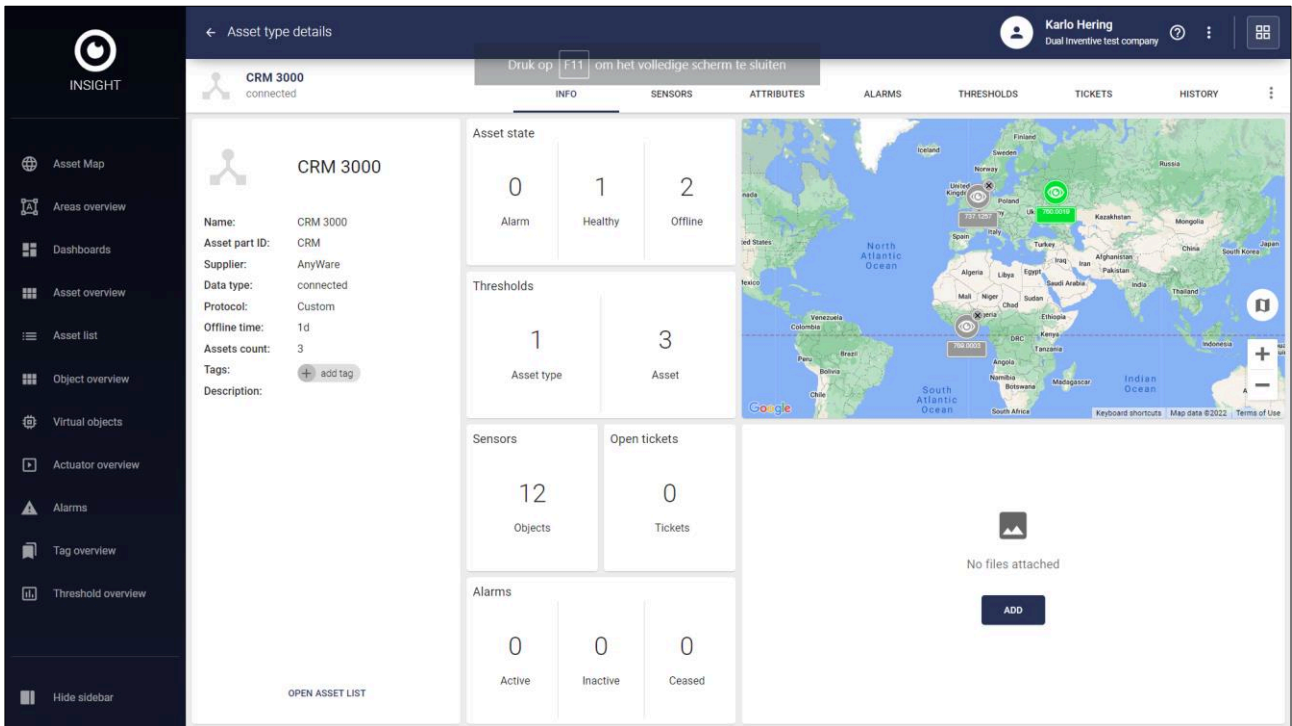

Figure 6-10: Asset type details CRM 3000s

6.6 Asset list

The Asset list shows a list of all available assets:

State	Name	Asset type	Last update	Tags	Temperature (0)	Temperature (1)	Accelerometer	Voltage	Conn
					PT1000	Internal	X Value Y Value Z Value	Sensor Value	Sign
	737.1257	CRM 3000	11.05.2022 14:18:41	+	22.74	n/a	247.00 -246.00 195.00	3.46	n/a
	760.0019	CRM 3000	21.10.2022 08:28:20	+	35.56	31.25	0.92 -9.81 -0.31	3.65	-12
	769.0003	CRM 3000	27.08.2021 10:15:15	+	n/a	n/a	n/a n/a n/a	n/a	n/a

Figure 6-11: Asset list

The Asset list has the following possibilities:



Click this icon to change the column settings. The new column settings are saved and will be shown every time the Asset list is opened.

Click any of the column headers to sort them by latest/oldest date and highest/lowest number.

Click an asset to show its detailed information (see section 6.4).

6.7 Dashboards

Dashboards are used to create a personal overview of the device's measured data. Dashboards are composed of one or more widgets. Each widget shows data in a different way, such as an overview of each CRM 3000's most recent temperature. Insight uses two types of widgets, the regular and the statistic widget. The scope of this manual is the regular widget because this widget is used for the CRM 3000. You can create new dashboards and edit existing dashboards. By editing dashboards, you can rename the dashboard and share it within your company.

6.7.1 Creating dashboards

1. Select 'Dashboards' from the Insight menu.

This overview shows all dashboards that have already been shared with you, or that you have made before. Select a dashboard to show its widgets in detail:

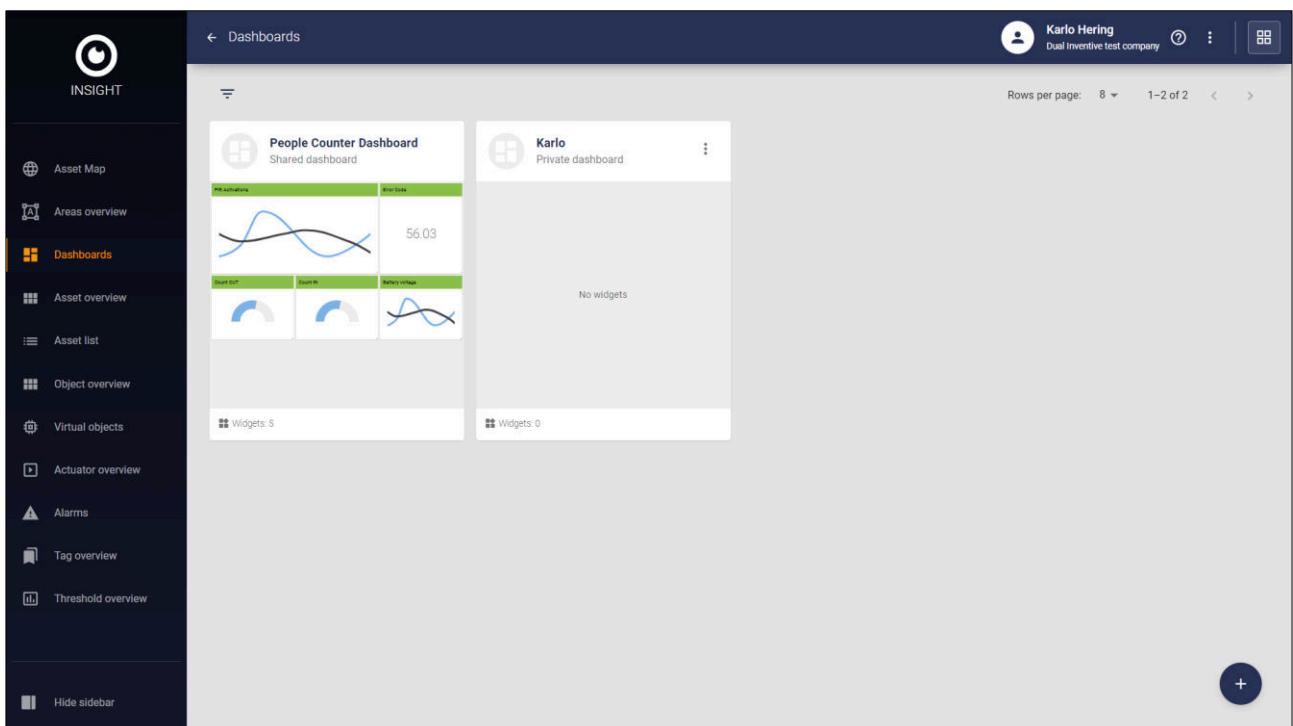

Figure 6-12: Dashboards

2. Click this button to create a new dashboard and give it a name.

After creating a new dashboard, you can add widgets to it.

6.7.2 Creating widgets

1. Click the dashboard (see Figure 6-12) for which you want to add one or more widgets.

The following screen appears:

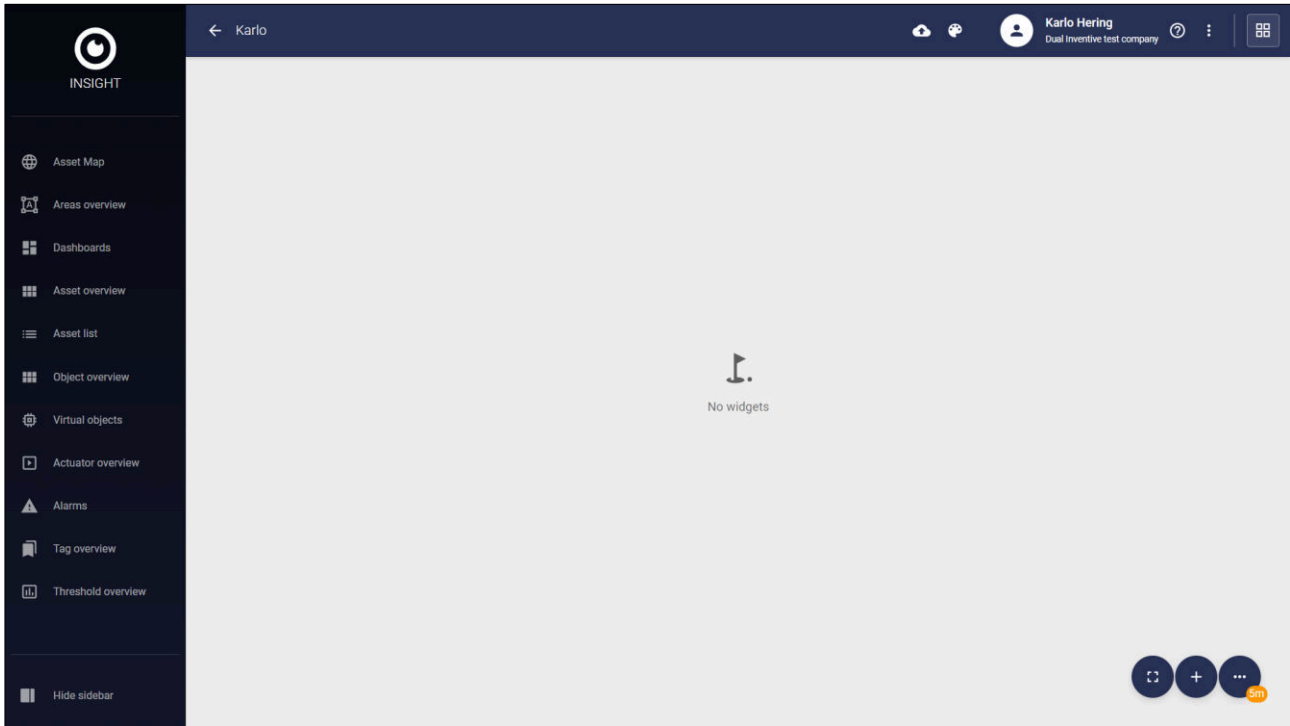

Figure 6-13: Widgets

2. Click this button for a full screen.
3. Click this button to update the last period (5 minutes to 1 year) of the current dashboard.
4. Click this button to create a new widget.

The following screen appears:

Figure 6-14: Add widget

1. Fill out the 'Widget title'. Click the pallet icon to change the widget's colour.
2. Select 'Widget type'.
3. Select 'Asset' for which CRM 3000 you want to display in the widget. Note: if there are more than 10 assets available, start typing the CRM 3000 name. This acts as a filter.
4. Select 'Resource' to select which sensor value of a CRM 3000 you want to display in the widget.
5. Click the button 'Add' to place the widget on the dashboard.

6.7.3 Editing dashboards



1. Click this button (see Figure 6-12) to edit the current dashboard. Note: only the user who created the dashboard can edit it.
2. If needed, rename the dashboard.
3. Tick the box to share the dashboard within your company if needed.

6.8 Virtual objects

Virtual objects are used to create different sensor values through calculations of existing sensor values. In this section, the use case 'Convert the CRM 3000's measured temperature in Celsius into Kelvin' is explained. After creating a virtual object, it can be added to a device. If needed, virtual objects can be removed from a device.

6.8.1 Creating virtual objects

1. Select 'Virtual objects' from the Insight menu.

This overview shows all virtual objects that have been shared with you, or that you have made before:

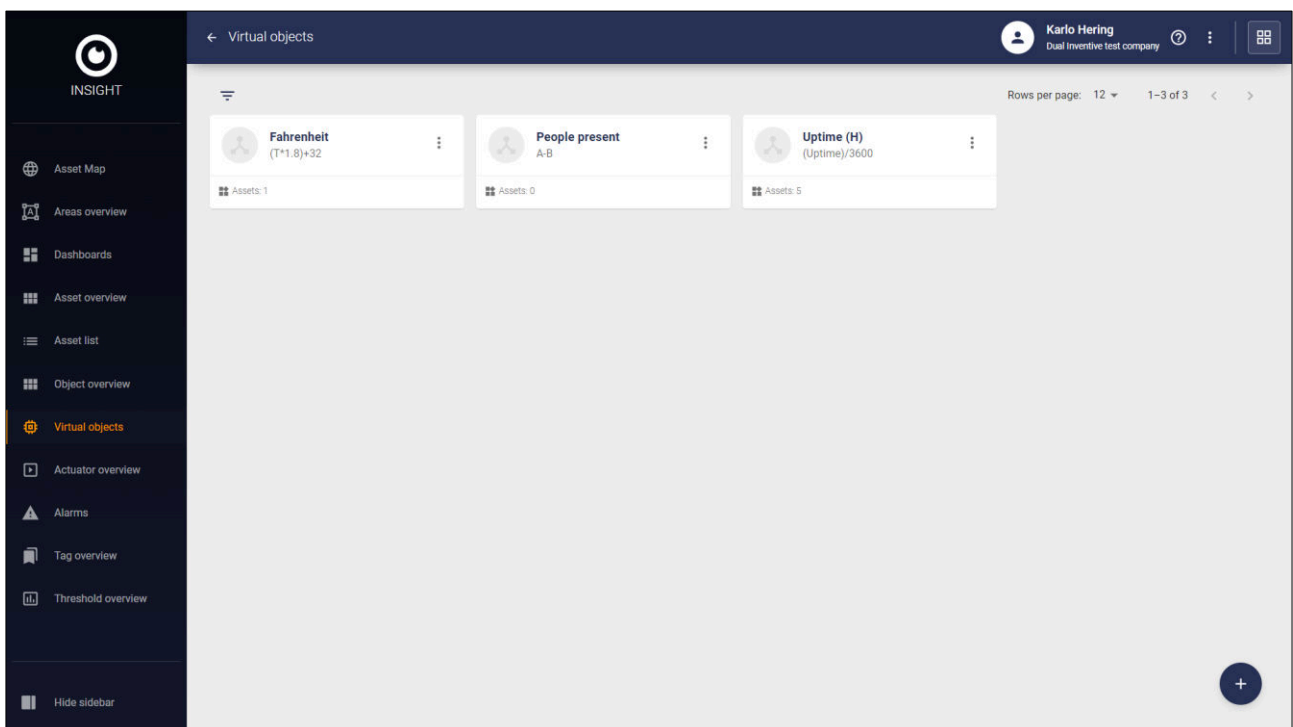

Figure 6-15: Virtual objects

2. Click this button to create a new virtual object and give it a name.

The following screen appears. It has already been filled out for the use case 'Convert the CRM 3000's measured temperature in Celsius into Kelvin':

Figure 6-16: New virtual object

1. Fill out the field 'Main info'. Give the virtual object a name and optionally a unit and a description. Units serve as indicators, such as Celsius, that will be displayed behind the sensor value.

2. Fill out the field 'Expressions and variables'. Enter the formula you want to apply to a sensor value. In this example, the formula 'K+273.15' is used to convert Celsius into Kelvin.

Start typing the variable. This can be any letter. Variables are used to indicate a sensor value. In this example, K is used as variable, which represents the temperature sensor of the CRM 3000. When entered in the field 'Expression and variables', the variable becomes configurable.

3. Fill out the field 'Variable K'. Select whether the variable should be a resource, or a different virtual object. In this example, 'Resource' is used.

In 'Object', select the sensor value to be used. In this example, 'Temperature' is used.

In 'Resource', select the value of this sensor; the maximum, minimum or the current sensor value. In this example, 'Sensor Value' is used.

For 'Instance', 0 is used in this example.

Optionally, 'Use previous sensor value' can be used if the current value needs to be compared to the previously measured value.

'Default value' can be set when no data is received, but a calculation still needs to be made.

4. Click the button 'Save'.

6.8.2 Adding virtual objects

To add one or more virtual objects to a device:

1. Navigate to the asset details of a device and select the tab 'Sensors' (Figure 6-8).
2. Click this button to Add a virtual object.

The following screen appears:

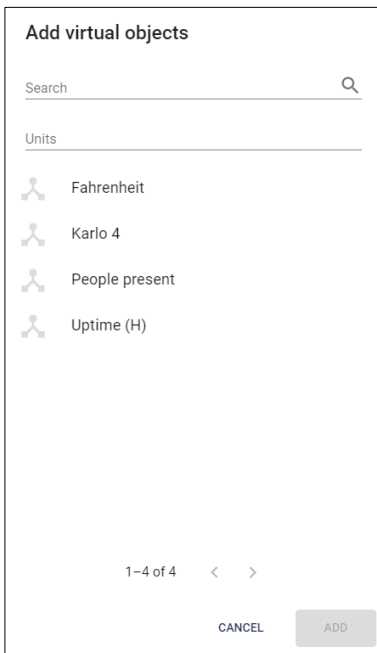

Figure 6-17: Add virtual objects

3. Select one or more available virtual objects. If needed, search for a specific virtual object by name.
4. Click the button 'Add' to add the virtual object(s) to the list of sensor values.

6.8.3 Removing virtual objects

To remove one or more virtual objects from a device:

1. Navigate to the asset details of a device and select Sensors (see Figure 6-8).
2. Click this button to remove one or more virtual objects.

6.9 Thresholds

The following possibilities are available for setting up thresholds:

- temperature;
- orientation detection to measure and warn users when the CRM 3000 has fallen off the track.

Thresholds can be set on multiple CRM 3000s at once. This can be done by:

- setting a threshold on multiple CRM 3000s from the asset list, up to a maximum of 10;
- setting a threshold on all CRM 3000s at once.

To set up a threshold:

1. Navigate to the device's asset details and select Thresholds (see Figure 6-8).
2. Click this button to set a threshold.

The following screen appears:

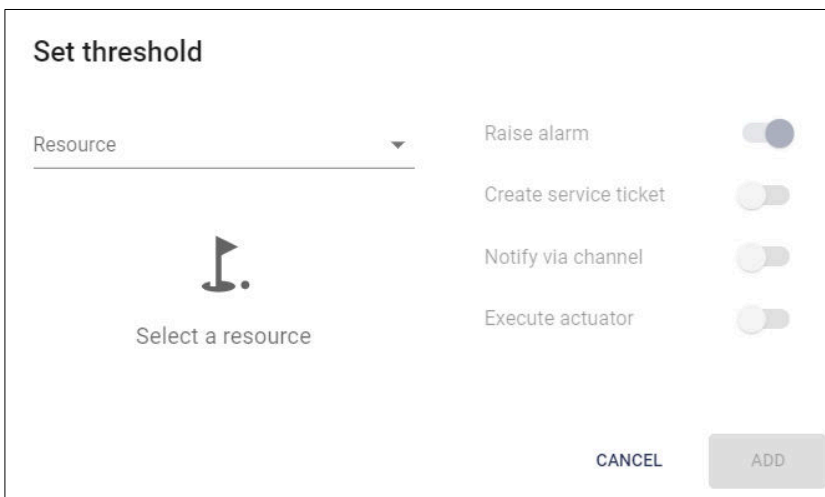

Figure 6-18: Set threshold

1. Select 'Resource' for the sensor to get alarmed for:
 - Temperature (see section 6.9.1).
 - Orientation detection (see section 6.9.2).
2. Choose what needs to happen when a threshold is exceeded:
 - Raise alarm. This is set by default. The asset has a special alarm state, paired with a different colour.
 - Create service ticket. This is not relevant for the CRM 3000.
 - Notify via channel. Select a notification channel to receive e-mail or push alarms whenever the threshold is exceeded (see section 6.10).
 - Execute actuator. This is not relevant for the CRM 3000.
3. Click the button 'Add' to set the threshold.

6.9.1 Temperature

Set threshold

Resource
PT1000

Type

Occurrence type Value
Counts 1

Raise alarm

Create service ticket

Notify via channel

Execute actuator

CANCEL ADD

Figure 6-19: Set threshold – temperature

1. Select 'temperature' as 'Resource'.
2. Select 'Type' to choose which criteria the measured value needs to trigger the alarm.
3. Set 'Occurrence type' to Counts to trigger an alarm after X consecutive values exceed the threshold. Set to Minutes to trigger an alarm after X minutes of the values exceeding the threshold.
4. Select 'Value' to choose to receive a message, once the CRM 3000 updates this to Insight, when the threshold is exceeded by setting the occurrence type to counts 1. One count is equivalent to 5 minutes. Increasing the number means the threshold needs to be exceeded x times before an alarm is raised and a notification is sent.
5. Click the button 'Add' to set the threshold.

6.9.3 Setting a threshold on multiple CRM 3000s at once (maximum of 10)

To set a threshold on multiple CRM 3000s at once for a maximum of 10 devices:

1. Navigate to the Asset list (see section 6.6).

The following screen appears:

The screenshot shows the 'Asset list' page in the INSIGHT application. The left sidebar contains navigation options: Asset Map, Areas overview, Dashboards, Asset overview, Asset list (highlighted), Object overview, Virtual objects, Actuator overview, Alarms, Tag overview, and Threshold overview. The main content area displays a table of CRM 3000 assets. The table has columns for State, Name, Asset type, Last update, Tags, PT1000, Internal, Accelerometer (X, Y, Z Values), Voltage, and Sensor Value. Three rows are visible, each with a checkbox in the State column. The first two rows have their checkboxes checked. A blue button with a pencil icon and a '2' notification badge is located in the bottom right corner of the table area.

State	Name	Asset type	Last update	Tags	PT1000	Internal	Accelerometer	Voltage	Conn		
							X Value	Y Value	Z Value	Sensor Value	Sign
<input checked="" type="checkbox"/>	737.1257	CRM 3000	11.05.2022 14:18:41	+	22.74	n/a	247.00	246.00	195.00	3.46	n/a
<input checked="" type="checkbox"/>	760.0019	CRM 3000	21.10.2022 10:28:20	+	27.54	25.00	1.23	-9.96	0.00	3.66	-30
<input type="checkbox"/>	769.0003	CRM 3000	27.08.2021 10:15:15	+	n/a	n/a	n/a	n/a	n/a	n/a	n/a

Figure 6-21: Asset list – select devices

2. Click the checkboxes (maximum of 10) to select the CRM 3000s.



3. Click this button and select 'Set thresholds' to set the threshold on all CRM 3000s.

6.9.4 Setting a threshold on all CRM 3000s at once (more than 10)

To set a threshold on all CRM 3000s at once for more than 10 devices:

1. Navigate to Asset overview, select the CRM 3000s (see Figure 6-10) and select Thresholds.

The following screen appears:

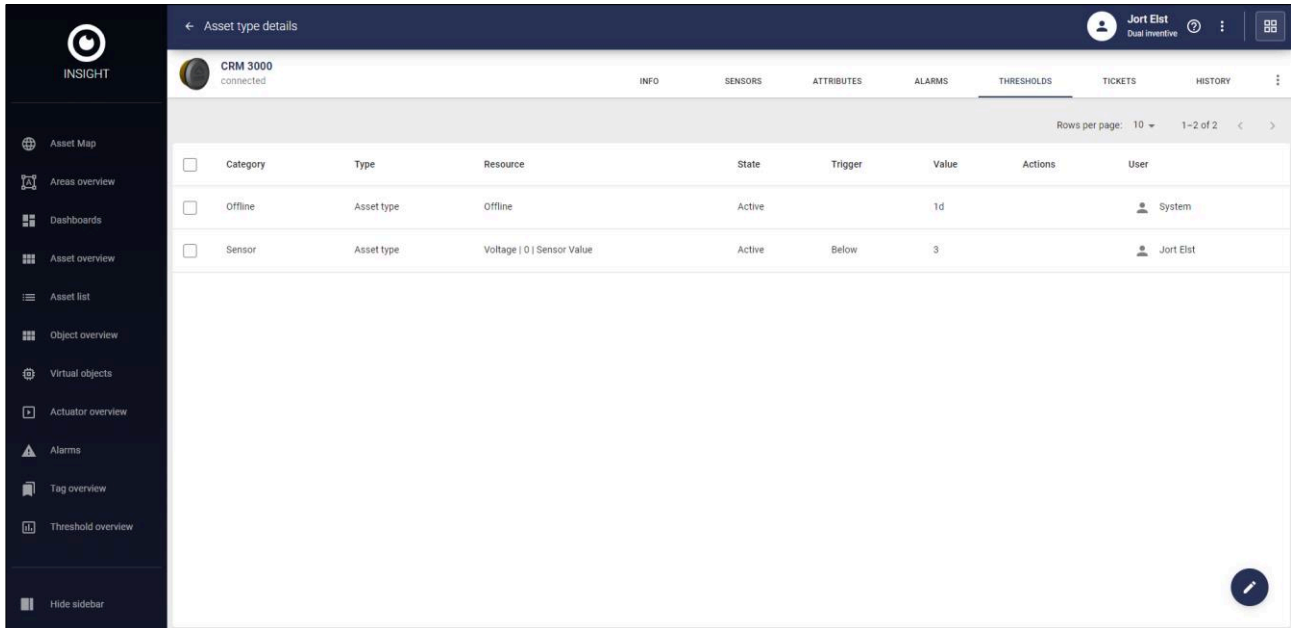

Figure 6-22: Asset list - select devices

2. Click this button and select 'Set thresholds' to set the threshold on all CRM 3000s.

6.10 Setting up notification channels



NOTE

Only administrators and users with access to Provisioning are authorized to set up notification channels.

Notification channels allow users to decide who and how notifications are received. You can:

- create new notification channels;
- edit existing notification channels.



1. Click this button to navigate to Provisioning.

2. Select 'Provisioning service'.

3. Select the menu 'Configuration / Notifications'.



4. Click this button to create a new notification channel.

The following screen appears:

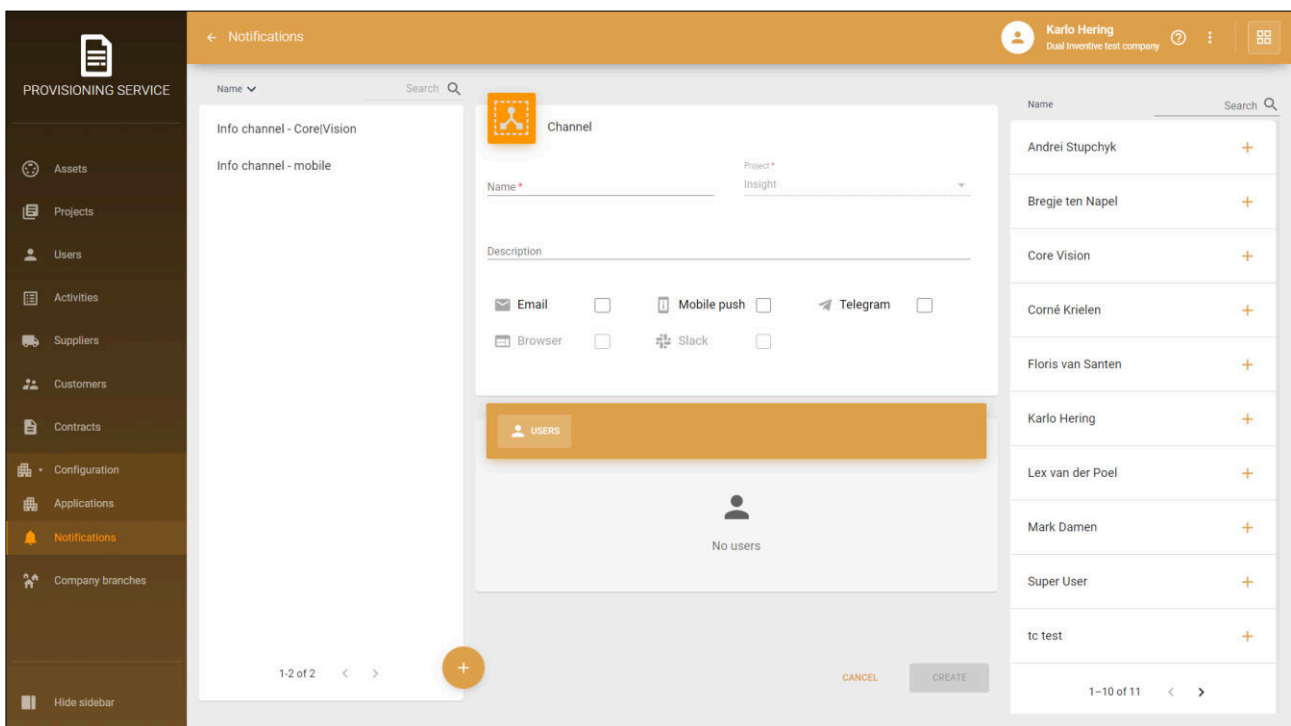

Figure 6-23: Provisioning service - notifications

6.10.1 Creating notification channels

To create one or more notification channels:

1. Give the channel a name and if needed, a description.
2. Select the type of notification: 'Email' or 'Mobile push'.

3. Add users to the channel. Search users in the right window and press + to add them.
4. Choose whether each user should receive the selected types of notifications.
5. Click the button 'Create' to create the new notification channel. The notification channel can now be selected when setting up thresholds.

6.10.2 Editing notification channels

To receive personalised notifications, the user can customise notification channels.

1.  Navigate to 'Settings' and scroll down (see Figure 6-4).

The following screen appears:

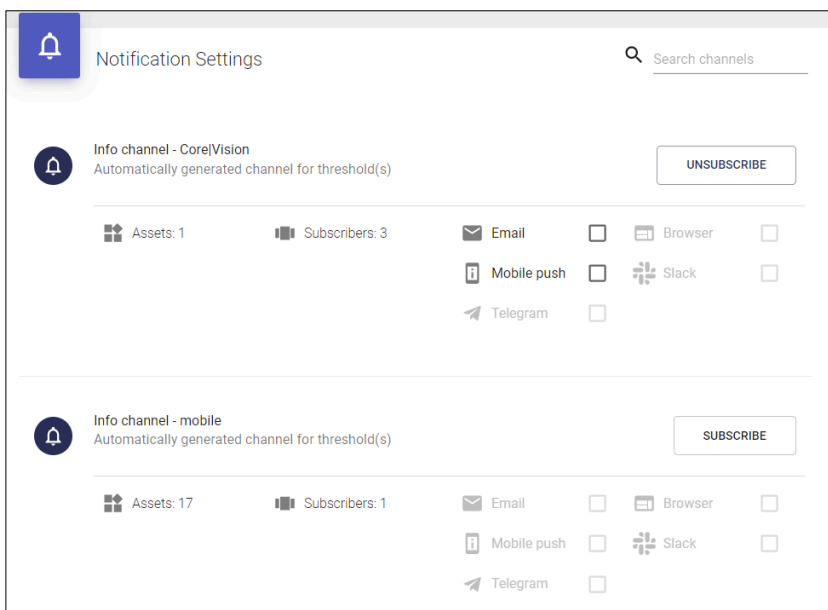

Figure 6-24: Notification settings

2. Click the button 'Subscribe' to receive notifications from the Info channel.
3. Select the type of notification: 'Email' or 'Mobile push'.
4. Click the button 'Unsubscribe' to stop receiving notifications from the Info channel.

7 APP 'THE RAILCLOUD - WORK MANAGEMENT'

This section describes special features that differ from Insight web and which are exclusive to the app 'The RailCloud - Work Management', also known as the Insight app.

7.1 Installing

Download (free of charge, iOS or Android) the Insight app on your smart phone or tablet. The device requires at least 70 MB of free space.

1. Visit the app store on your device and enter 'RailCloud' (iOS) or 'Work management Dual Inventive' (Android) into the search field.
2. Download the Insight app.

7.2 Logging in

Once installed and opened, you will be prompted to log in with your Insight credentials. When logged in, the Asset map is displayed by default. All menu items in the app work like in Insight web.

7.3 Enabling / disabling personal notifications

The app can be used to customise your notification channels:



1. Touch this button to open the menu.



2. Touch this button (next to your avatar) and select 'Channels' for an overview of all the channels to which you are subscribed.

3. Use the slider to disable or enable notifications.

4. Additionally, touch any channel to select per notification type whether it should be enabled or disabled.

7.4 Map features

The map in the app has a few different buttons compared to Insight web:

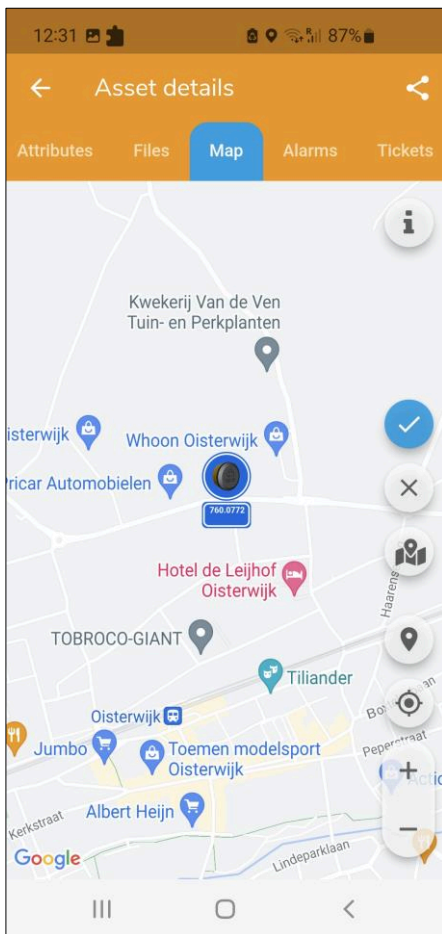







Figure 7-1: Insight app - map

LEGEND	
	Show a route from the user's location to the asset's location.
	Centre the map on the asset's location.
	Centre the map back to the current location.
	Edit to update the asset's location. Touch anywhere on the map to relocate the asset's location and confirm to update.
	Immediately jump to the location of your device and sync the location with the location of your device.

8 CHANGING LOCATIONS

The CRM 3000 cannot automatically update its location. If needed, the asset's location can be changed manually through Insight web and/or the app. There are two possibilities:

- changing the location by selecting a new location manually;
- changing the location by synchronizing it with your smart device's location.

8.1 Changing manually locations

The location of a CRM 3000 can be changed manually through Insight web or the app:

1. Insight web: go to 'Asset list' (see section 6.6) and select the device. You will see the CRM 3000 on the map.

Insight app: navigate to 'Map' (see Figure 7-1) to see the device's location.



2. Click this button.

3. Select where you wish to place the CRM 3000. Zoom in and out with the scroll wheel of your mouse or use the + and - buttons on your smart device.

4. Click the check button to confirm the device's new location.

5. Click the cancel button to cancel the new location.

8.2 Synchronizing with a smart device's location

The location of a CRM 3000 can be changed by synchronizing it with a smart device's location through the app:

1. App: navigate to Map (see Figure 7-1) to see the device's location.



2. Click this button to update the location.

3. Select the location you wish to move the asset to by tapping anywhere on the map.



4. You can also press this button to immediately jump to the location of your device and sync the location with the location of your device.

5. Confirm the selection to update the asset's location.

9 TROUBLESHOOTING



NOTE

If you frequently receive warning and/or error messages, please contact Dual Inventive.

Refer to Table 9-1 below to follow up on warning and error messages. If the solution does not work, please contact Dual Inventive.

DESCRIPTION	SOLUTION
The CRM 3000 is offline.	<p>If a CRM 3000 is offline, try the following:</p> <ol style="list-style-type: none"> 1. Ensure the area you are in has a good NBloT coverage. If you are unsure about this, contact Dual Inventive for assistance; 2. Wait for 24 hours. The CRM 3000 is built to automatically reset itself after 24 hours in case it is offline.
Notifications from the CRM 3000 are not received.	<p>In case you do not receive notifications from the CRM 3000, try the following:</p> <ol style="list-style-type: none"> 1. Ensure a threshold has been set on the CRM 3000 and that value has been exceeded. 2. Check if a notification channel has been assigned to this threshold and whether the specific user is assigned to this channel. 3. Check your personal settings to ensure you are assigned to the notification channel and the expected notifications are enabled. (See section 6.10 for setting up notification channels).
The CRM 3000 does not show certain points of data in the graphs.	<p>The CRM 3000 does not update its status to Insight retroactively if it is offline. If there are data gaps in Insight, this may be related to the network quality of the area in which the device is located.</p>

Table 9-1: Warning and error messages

10 SERVICE

The CRM 3000 is designed to be maintenance free for 5 years. In the case of problems, please contact your Dual Inventive contact person for assistance.

11 CONTACT DETAILS

The Netherlands:

BELGIËSTRAAT 5 | 5061 KG OISTERWIJK | THE NETHERLANDS

Telephone: +31 (0)13 5339969

Email: info@dualinventive.com

Website: dualinventive.com

United Kingdom:

**UNIT 3, KESTREL COURT | FIRST AVENUE | DONCASTER, DN9 3RN |
UNITED KINGDOM**

Telephone: +44 (0)3300 169033

Email: info@dualinventive.com

Website: dualinventive.com
